



Civil Engineering

INSTALLATION GUIDE



TABLE OF CONTENTS

Table of Contents

1. Scope	3
2. About Eurobent	5
3. Environmental impact	7
4. Supply, Packaging and Labelling	9
5. Unloading, Storage and Transportation	11
6. After delivery inspection	14
7. Equipment recommended on site	16
8. Personal protective equipment	18
9. Qualification for installer	20
10. Weather conditions for installation	22
11. Subgrade preparation	24
12. Installation	26
12.1. GCL placement	28
12.2. Panel overlaps and seaming	28
12.3. Installation on slopes	34
12.4. Anchor Trenches	34
12.5. Connections & Penetrations	35
13. Inspection	38
14. Damage repair	40
15. Preparation for placing soil cover	42
16. Soil cover placement	44
17. Hydration	46
18. Terms & Conditions	48
18.1. Installation form	50
18.2. Goods receipt form	52

SCOPE

01

1. SCOPE

The following installation recommendations are general guidelines for GCL installation. They are provided as a general statement and are not a direct substitute for specifications for the project. In the event of a discrepancy, the project specification will override these recommendations.

These installation guidelines are not intended to establish a specific procedure for all climatic, geographic, hydraulic, or topographic conditions that may exist at a particular installation site. Appropriate installation procedures for unusual site conditions should be modified as necessary to maintain the integrity of the GCL and adjacent site. The information contained in this document has been prepared by Eurobent Sp. z o.o. and is, to the best of our knowledge, true and accurate.



The manual is based on experience and standards:

- ASTM D5888 (Standard Guide For Storage and Handling of GCLs)
- ASTM D 6102 (Standard Guide For Installation of GCLs),
- ASTM D 5889 (Standard Practice for Quality Control of GCLs),
- ASTM D 6072 (Standard Guide for Obtaining Samples of GCLs),

which should be considered as supplementary to the manual.

The user of these guidelines should establish appropriate safety and health practices and determine the applicability of legal restrictions prior to use.

Final determination of suitability for the intended application rests solely with on the user, who is responsible for proper installation of the GCL. This information is subject to change without notice.

Eurobent does not warrant or assume responsibility for the results obtained from these installation guidelines or for the proper application of GCL in any project, as it is the designer's responsibility to determine what material is appropriate for a particular project.

These instructions should be read in relation to the contract specifications and drawings. They are intended to provide guidance in normal installation situations and are provided on the request. If you have questions about the design, unusual installation problems, or any concerns, contact your designer or Eurobent for further advice. In all situations, the installer is responsible for the installation.



ABOUT EUROBENT

02

2. ABOUT EUROBENT

Eurobent Sp. z o.o. is a Polish company from Lower Silesia.

Eurobent is a producer of Geosynthetic Clay Liners (GCL), also called bentonite mats, serving as a sealing barrier specialized in a permanent protection against water penetration and leaching of toxic substances. A typical GCL construction consists of two layers of geosynthetics needlepunched together enclosing a layer of bentonite. A polymer membrane can also be coated on the GCL.

Eurobent entered the GCL production market in 2008. The company is a team of young, dynamically developing people. Thanks to the high standards of its products and the professional service Eurobent has earned the trust and respect of one of the largest GCL consumers in the European market and beyond. At the same time, thanks to many years of experience in the field of geosynthetics production, the company has been able to develop invaluable knowledge in the production of bentonite mats, which has enabled them to become an innovative and acknowledged competitor on the international market.

The company consists of skilled staff committed to provide the best service and products available on the international marketplace.

Eurobent's laboratory technicians constantly undertake numerous tests on our products to ensure that their high standards are constantly maintained.

Eurobent is committed to constantly reviewing the service we provide, thus ensuring that we not only meet all of our customers' needs and requirements but exceed them. The company aims to provide the highest quality product that can be produced in the field of GCL in Europe and also ensure that it would be manufactured, stored and transported in the way to minimize their impact on the environment. The customers can be sure that they purchase an environmentally friendly product from a company that is dedicated and committed to environmental protection.



Offered product is an isolating low permeable bentonite mat which is constructed from two component parts: PP geosynthetics & bentonite.

The excellent absorption properties of bentonite renders the GCL impermeable.

The self-sealing properties of the bentonite layer secures the integrity of the product in the event of damage to the geosynthetic layers. This distinguishes of offered product from the others sealants available on the market. It also has the following additional advantages: enhanced mechanical and waterproofing parameters, extreme toughness and durability, a double lining system, self-healing properties, puncture resistance, eco-friendliness, verified and proven track record for quality.

ENVIRONMENTAL IMPACT

03

3. ENVIRONMENTAL IMPACT

All materials used for the production of EUROBENT bentonite mats do not contain any hazardous or toxic substances and do not affect the environment in any way. No harmful substances are released to the EUROBENT bentonite mat in case of fire hazard.



ENVIRONMENTAL IMPACT

**SUPPLY,
PACKAGING
AND LABELLING**

04

4. SUPPLY, PACKAGING AND LABELLING

The GCL is labelled according to EN ISO 10320 for easy identification after unloading and during installation. Each roll shall be marked with the following information:

1. Manufacturer's name
2. Product identification
3. Roll number

EUROBENT is usually provided in rolls with a width of 5,1 m and a length of 40 m. Rolls can be also offered in other dimensions, depending on customer needs. The range of possible widths is 1 m to 5.1 m, and they can have the length specified by the customer. Average roll diameter is approximately 60 cm, and the weight is approximately 1000 kg. Eurobent GCL are wound on plastic tubes with an inner diameter of 100 mm. Every roll is packed in a plastic UV resistant sleeve.

Eurobent supplies a 20 kg bag of bentonite powder for each roll 5,10 x 40 m. For rolls with prefabricated overlaps we supply one bag to every 3 rolls. The bag is meant for application in the overlapping areas.

Each roll is equipped into a set of two belts. It is recommended while unloading from the truck to put a steel pipe inside to prevent bending of the roll.



UNLOADING, STORAGE AND TRANSPORTATION

05

5. UNLOADING, STORAGE AND TRANSPORTATION

Unloading

The party directly responsible for unloading the rolls should refer to this manual prior to arrival of the material in order to make sure they have proper unloading equipment and know the procedure. The unloading and on-site handling should be appropriately supervised. During the unloading procedure all material lot and roll numbers should be recorded and compared to the packing list. In addition, each roll of GCL should also be visually inspected to determine if there is no perforation in the packaging or other visual material damage.

Accumulation of some moisture within roll packaging is normal and does not affect the product quality.

The exact nature and extent of the damage should also be indicated on the CMR / Bill of Lading along with the specific lot and roll numbers of the damaged materials. Photos of the damaged goods on the truck are required.

Unloading the truck at the construction site is carried out either by forklifts, wheel loaders, excavators or by means of built-in truck cranes.

A suitable crossbeam can be used also for the unloading. The crossbeam pipe (with a maximum diameter of 8 cm) is thrust through the core of the rolls and attached at the ends with chains, belts or ropes to the crossbeam. The unloading is carried out upwards.

If there is no crossbeam available, at least 2 belts are wound around the rolls. The unloading is carried out smoothly upwards or laterally via e.g. crane.

Another unloading option is a forklift, to which a stable mandrel is attached. The truck is unloaded from the back in this manner. Under no circumstances should the rolls be dragged from the truck since the geosynthetic clay liner may be damaged significantly.

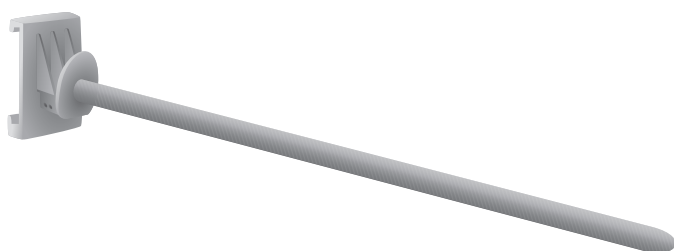

The GCL may also be delivered in shipping containers. In these cases, different unloading equipment and techniques must be employed. Because of limited access to the GCL rolls, it is usually necessary to utilize an extendable-boom forklift with a pole carpet (stinger) attachment.

The rolls are removed by inserting the stinger through the roll cores and lifting/pulling the rolls from the container. To each container we add several loading straps - thanks to that rolls can be tied up - it makes it easier to remove the rolls from the container.

Storage

The GCL may be stored at a project site indefinitely, provided that proper storage procedures are followed.

Firstly, a dedicated storage area should be identified. This area should be leveled, dry, well drained, and located away from high-traffic areas of the job site. In the warehouse and on site, bentonite mats should be placed on underlying material (wooden beams, pallets, plastic profiles etc.) to avoid unnecessary material wetting by rain during storage.

Rolls should not be stacked in more than 4 rolls high.

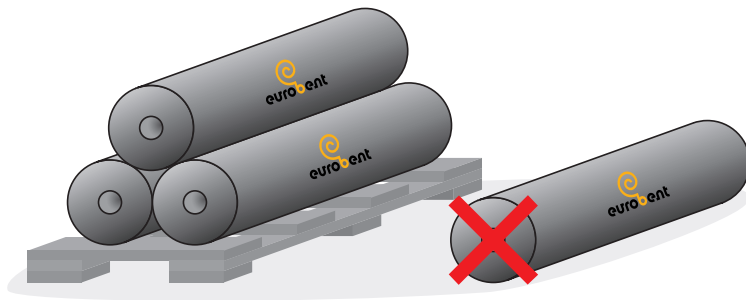
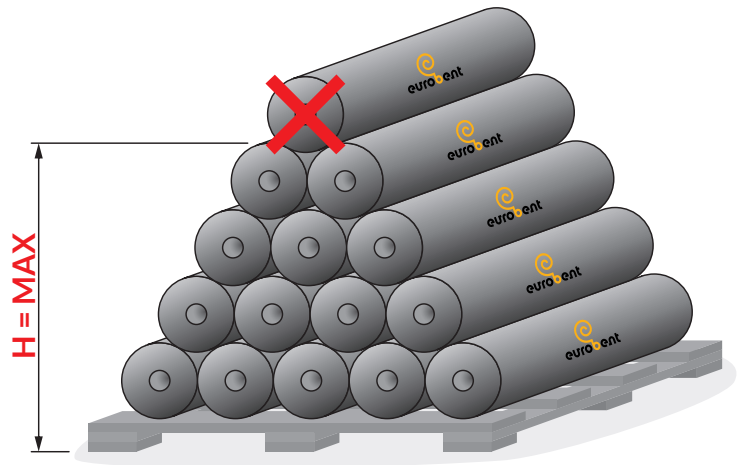

Long-term storage of material in a warehouse or on a construction site requires periodic inspection of the condition of the packaging. The polyethylene sleeves of the GCL rolls should be examined for any obvious rips or tears. Sleeve damage should be repaired immediately with adhesive tape or additional plastic sheeting. At this point it is also recommended to examine the labels - if they were displaced in transit, they should be taped to the roll.

EUROBENT should not be directly exposed to the elements during the storage. Cover all rolls with a plastic sheet or a tarpaulin. Do not remove the plastic sleeves prior to installation.

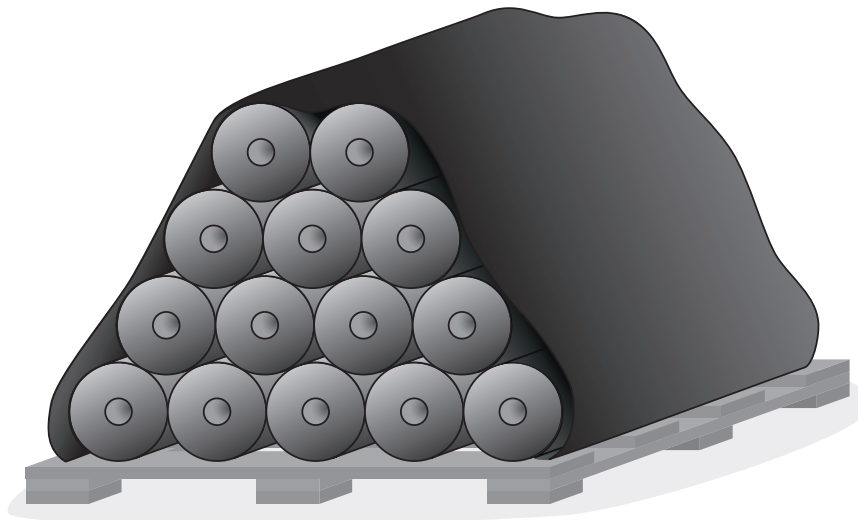

NOTE:

The temperature of the surrounding environment has no degrading effect on the quality of EUROBENT mats even when stored for long periods.

AFTER DELIVERY INSPECTION

06

6. AFTER DELIVERY INSPECTION

1. Each roll shall be visually inspected when unloaded to determine if any packaging or material has been damaged during transit.
2. Repairs to damaged GCL shall be performed in accordance with installation manual:
 - a. Rolls with visible damage shall be marked and set aside for closer examination during deployment.
 - b. Minor rips or tears in the plastic packaging shall be repaired with moisture resistant gluing tape prior to being placed in storage to prevent moisture damage.
 - c. GCL rolls delivered to the project site shall be only those indicated on GCL manufacturing internal test reports.
 - d. In the case of GCL, the presence of flowing water in the package requires the removal of water from the roll package. Free flowing water in the packaging of unreinforced GCL is not a reason to reject the roll.

Preserve integrity and readability of roll labels.



AFTER DELIVERY INSPECTION

**EQUIPMENT
RECOMMENDED
ON SITE**

07

7. EQUIPMENT RECOMMENDED ON SITE

The QCA inspector shall verify that proper handling equipment exists which does not pose any danger to installation personnel or risk of damage or deformation to the liner material itself. Suitable handling equipment is described below:

1. Spreader Bar Assembly – a spreader bar assembly shall include both a core pipe or bar and a spreader beam. The core pipe shall be used to uniformly support the roll when inserted through the GCL core while the spreader bar beam will prevent chains or straps from chafing the roll edges;
2. Stinger – a stinger is a rigid pipe or rod with one end directly connected to a forklift or other handling equipment. If a stinger is used, it should be inserted to its full length into the roll to prevent excessive bending of the roll when lifted;
3. Straps – a properly structured and supported pole or “carpet puller” can be used to unload GCL Rolls onsite. As an alternative, straps with appropriate lifting capacity, located across the roll, can be used as one of the method of lifting and unload GCL rolls;
4. Excavator (tracked or wheeled) or front-end loader. Equipment should be suitable for the anticipated load;
5. Sealing paste - EUROPASTE preferred;
6. Carpet knife or safety knife;
7. Felt pens or other pens to write on geotextiles;
8. Measuring tape;
9. Broom;
10. Tape;
11. Geomembrane welding machine.



PERSONAL PROTECTIVE EQUIPMENT

08

8. PERSONAL PROTECTIVE EQUIPMENT

Respiratory, eye, hand and body protection may be recommended when working with EUROBENT GCL. Safety is key, so taking the necessary safety precautions is a must



Safety Eye protection



Dust mask



Safety Hazard Clothing



Glove



PERSONAL PROTECTIVE EQUIPMENT

QUALIFICATION FOR INSTALLER

09

9. QUALIFICATION FOR INSTALLER

Recommendations:

The installation team must be familiar with EUROBENT installation guidelines and be trained in GCL installation.

Installer shall have experience installing GCLs on at least 5 projects and have installed a minimum of 500 thousand m² of GCL materials.



The manual is based on experience and standards:

- The suitability of the materials used as documented by certificates and statements from authorized testing institutes.
- Documentation of the specific attestations or delivery notes of the materials used at the construction site involved.
- Control during the execution itself according to the manufacturer's technology:
 - visual inspection of the underlayment before the actual installation,
 - visual inspection of the connections with inspection of the width of the coverage of the EUROBENT bentonite mats,
 - visual inspection of detail workmanship,
 - step-by-step handing over of the insulation system as a covered structure before installation of the following layers.



WEATHER CONDITIONS FOR INSTALLATION

10

10. WEATHER CONDITIONS FOR INSTALLATION

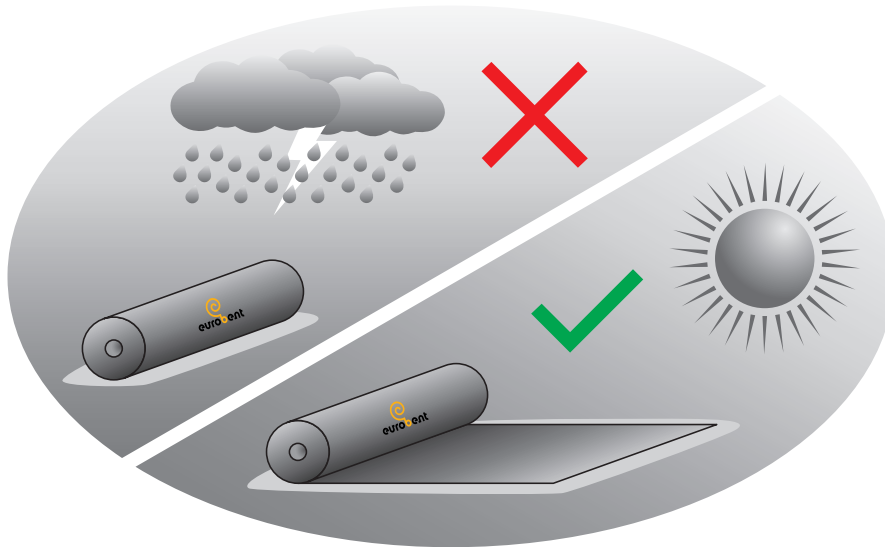

Light rainfall should not affect the EUROBENT installation provided that the deployed panels are covered and protected with 300 mm of topsoil (or equivalent) within 2 hours from first contact with light rain. During heavy rainfall EUROBENT panels shall be covered with a tarpaulin or plastic sheet if there is not enough time to complete the top layer deployment on the mat.

Avoid placing EUROBENT panels in areas where water runs off unless the panels can be immediately covered (with 300 mm soil cover or equivalent).

In the event of EUROBENT GCL gets wet before it is covered, it is best to contact Eurobent team. to determine if the GCL may still be useful. It depends on the degree of swelling of the bentonite inside the mat.

Puddles should be removed prior to soil application on the GCL. Slight movement on the wet bentonite mat during installation is possible, but should be minimized as much as possible.

Special care must be taken to ensure that the panels have not shrunk, thereby reducing the overlap area. If this is the case the overlaps must be filled in following the guidelines of the repair section GCL of this manual.

As demonstrated by freeze-thaw -and heat and rain tests, GCL does not change its properties under their influence.



WEATHER CONDITIONS FOR INSTALLATION

SUBGRADE PREPARATION

11

11. SUBGRADE PREPARATION

When installing EUROBENT GCL on a soil subgrade, the finished surface should be smooth without any abrupt elevation changes, voids, cracks, ice, or standing water. In addition it should be firm and unyielding, and compacted to a degree so that deployment or other construction equipment does not leave tracks or ruts greater than 25 mm in depth.

Surface, on which you plan to install the EUROBENT GCL must be free of sharp rocks, organic matter and other objects larger than 50 mm. The subgrade should be compacted at least 90% of its proctor density. While compacting with a smooth-wheeled or rubber-tired roller, try to keep the surface free of water. The GCL may be installed on a frozen subgrade, however only if the subgrade soil in the unfrozen state meets the requirements listed above.



Notwithstanding the above requirements, the subgrade surface must also be prepared in strict accordance with the project drawings and specifications, and the engineer's approval of the subgrade must be obtained prior to material deployment.

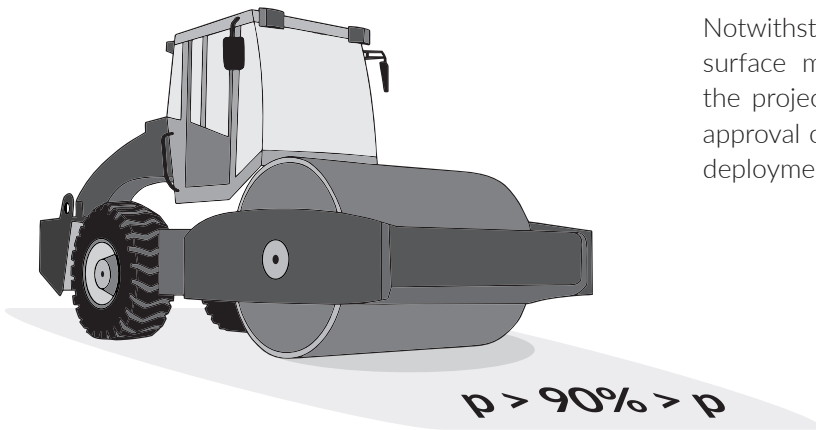

SUBGRADE PREPARATION

INSTALLATION

12

12. INSTALLATION

EUROBENT GCL rolls should be transported to the point of application in their original packaging with label identification and in accordance with the guidelines. The surface placement of the GCL (i.e. which side faces up) may be important if the GCL contains different types of geosynthetics. Always check with the designer or project manager to determine which face up GCL to lay. If a specific orientation is not indicated or required, unroll the GCL from the bottom rather than pull the flap from the top. Care should be taken when removing the packaging to avoid damaging the rolls. GCL rolls should not be freely unrolled down the slope.

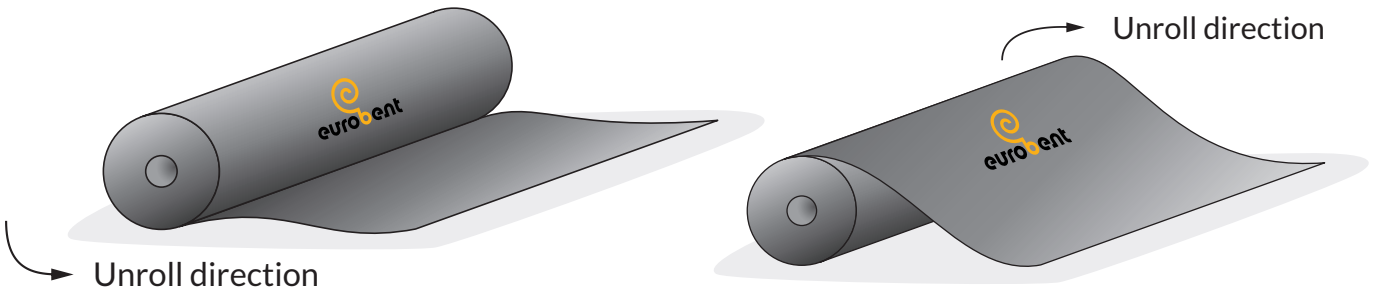

Equipment which could damage the GCL should not be allowed to move directly on it. Allowable equipment which may be utilized on the GCL is limited to lightweight ATVs with a maximum bearing capacity of 5 psi (21.5 kPa). Care should always be taken in the operation of any equipment on the GCL so as to avoid sudden starts and stops, abrupt turns, or other maneuvers that could damage the GCL.

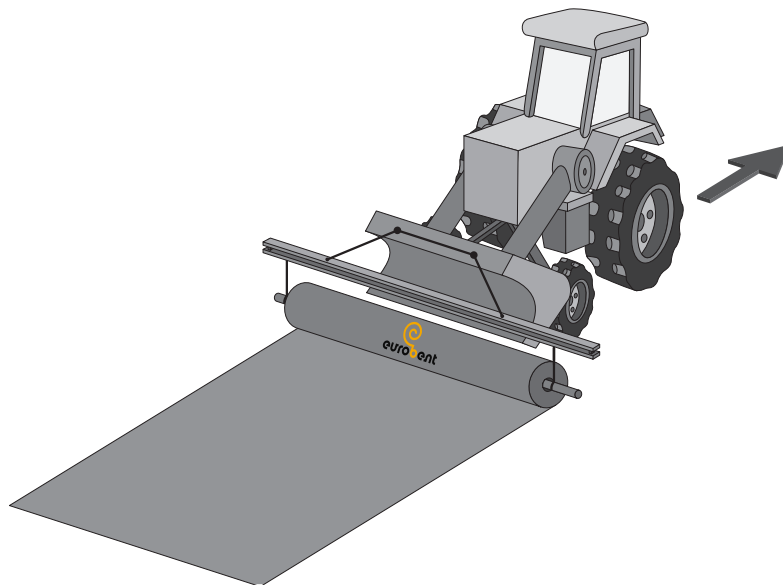

To minimize the traffic on EUROBENT GCL, installation can be accomplished by unrolling the GCL in front of a vehicle traveling backwards. If ruts or other damage to the substrate occurs at the installation site, these should be repaired before further laying of GCL or other material. Alternatively, if sufficient access is available, the GCL roll can be unrolled by hanging it from a spreader bar at the top of the slope and using a group of workers and equipment to unroll the material from the roll and pull it down the slope.

Regardless of the deployment method, care must be taken to minimize the extent to which the roll is dragged across the subgrade or other surface in order to prevent damage to the GCL. Care must also be taken when adjusting the GCL panels to avoid damage to the geotextile surface by the subgrade or another adjacent geosynthetic material such as a textured geomembrane. A temporary geosynthetic/geomembrane sheet, commonly known as a slip sheet or rub sheet, may be used to prevent or reduce friction damage during placement.

12.1. GCL placement

EUROBENT GCL shall be placed in a way that longitudinal joints are parallel to the slope direction. Transversal joints should also be located a minimum of 1 m from the toe and crest of any slopes steeper than 4H:1V. End seams on slopes should be used only if the liner is not expected to be in tension and interface friction testing confirms this.

EUROBENT GCL should be placed to lie flat, without any folds, especially at the exposed edges.

Panels should not be installed in standing water or during rain. To ensure proper GCL performance, panels shall be covered with soil, geomembrane or other cover layer at the end of the working day.

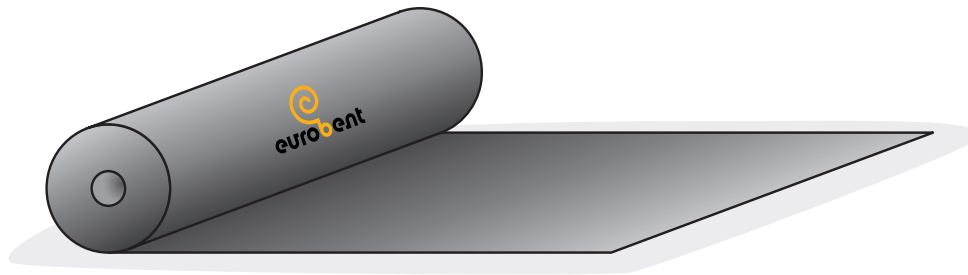

12.2. Panel overlaps and seaming

GCL overlaps are formed by overlapping adjacent edges. Ensure that the overlap area is not contaminated with loose soil or other debris.

Do not walk or drive over overlap areas.

Overlaps shall be designed to be arranged in the direction of the slope in a manner that prevents the possibility of flow into the overlap zone (tile application principle).

T-shaped overlaps (cross-connecting three or four panels at one point) should be kept to a minimum.

Two adjacent overlaps at the ends (cross overlaps) are not permitted.

Overlaps at low points should be avoided.

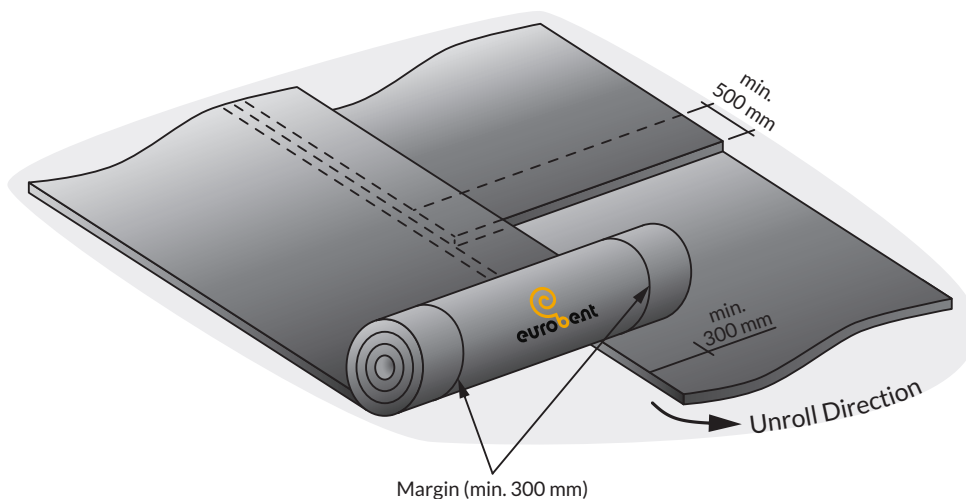

Unless otherwise specified, the minimum longitudinal overlap dimension should be 300 mm. EUROBENT edge lapping lines allow alignment during unrolling. The lines can be printed by the manufacturer if required by the project specification.

Transverse overlaps should be similar but the minimum overlap should be 500 mm.

EUROBENT edges can be printed according to customer's request. The standard overprint is two lines, where one of them is 15 cm from the longitudinal edge of the mat, but this can be customized. At Eurobent it is possible to print the name of the product or the project on the edge of the mat.

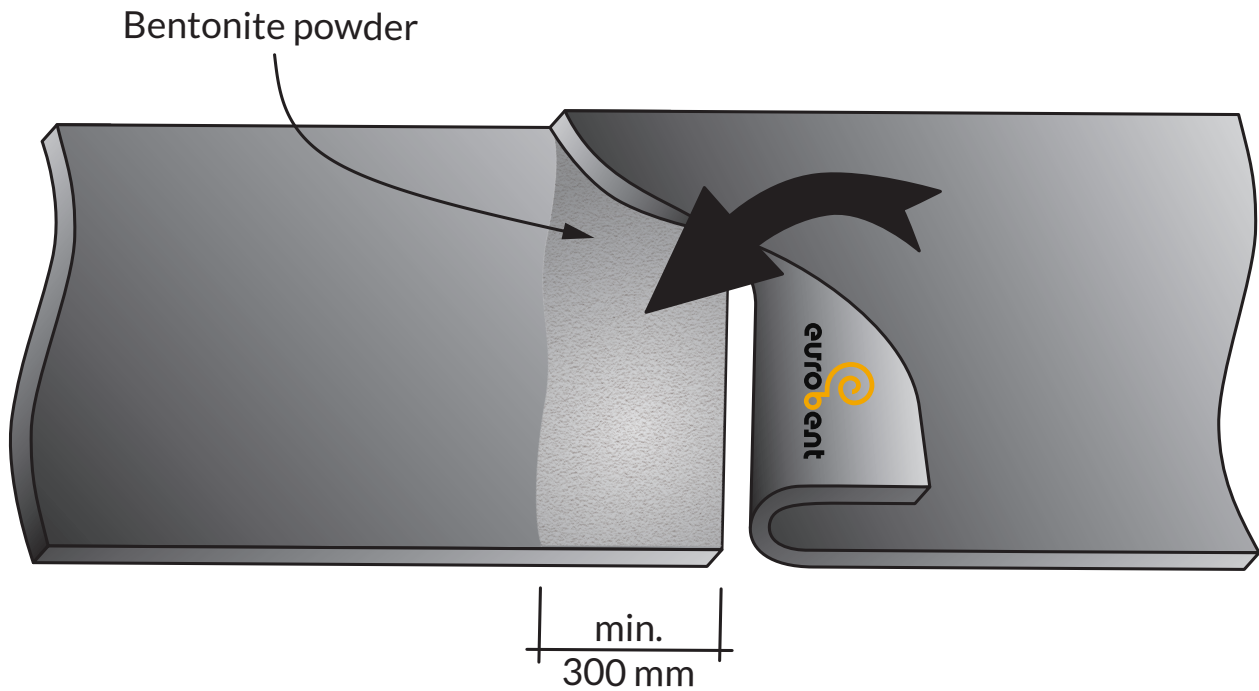

Care should be taken to maintain these overlap dimensions during covering, in all climatic conditions.

It may be necessary to place sandbags or other approved ballast over the overlap areas to prevent uplift in strong winds. Rolls should be adjusted to smooth out wrinkles or folds between adjacent panels, leaving adequate overlap and should be free of wrinkles, folds when covered.

Longitudinal overlaps:

It is necessary that the woven side of EUROBENT types overlaps at least 300 mm of nonwoven side, that has to be first impregnated with bentonite delivered in bags.

Transverse overlaps:

It is necessary that the woven side of EUROBENT types overlaps at least 500 mm of nonwoven side, that has to be first impregnated with bentonite delivered in bags.

NOTE:

In case of design requirement the longitudinal edges of EUROBENT rolls can be prefabricated with bentonite powder at the production stage.

Bentonite powder:

These overlapping edges are rolled upwards and bentonite similar to that used in the product shall be poured in a suitable manner over the width included in the design (200 - 300 mm) continuously along all edges of the seam, typically 0.8 kg/m.

After placing the bentonite powder in the overlap zone, place the adjacent EUROBENT roll in this area. If using a bentonite paste, this should be done shortly after applying it to avoid drying out the wet bentonite.

EUROBENT GCL is also available in a CS version (with an additional PE geomembrane layer), which ensures complete water impermeability. The geomembrane can be fixed in three ways, depending on customer guidelines:

- The membrane is glued over the whole surface (no free welding areas)
- As attached sketch No 1 – on one side free welding strip (area without glue)
- As attached sketch No 2 – on both sides free welding strip (area without glue)



Overlapping

One of the most important parts of the GCL assembly is connecting the individual panels together. To do this, the overlap joints must be made correctly. Here we will focus on joining GCL CS to each other.

NOTE:

The membrane in CS shall always face the side of water pressure, therefore two scenarios can occur during installation and assembly:

Geomembrane on the bottom

1. The GCL shall be folded so that the geomembrane can be visible.
2. The surface of the geomembrane shall be cleaned with acetone or similar agent. This action secures then integrity of combining. Clean and dry membrane surface before combining is a must.
3. The geomembrane of the panel 1 shall be covered with geomembrane of the panel 2, creating overlap.
4. The tape shall be placed in the middle of the combining spot, so that the half of the tape shall be on side 1 and the other half on the side 2 of the combining line.
5. After combining the geomembranes, left GCL shall be unfolded, covering the geomembranes.
6. The bentonite shall be poured on the edge of one panel (in this case 1 one).
7. The panel 2 shall be unfolded, covering the layer of bentonite and left panel.
8. Now the panels are ready for the next phase of the combining. There shall be some space without bentonite for the leister.
9. The overlap shall be combined with leister in order to secure the Integrity of the bond and avoid the separation.

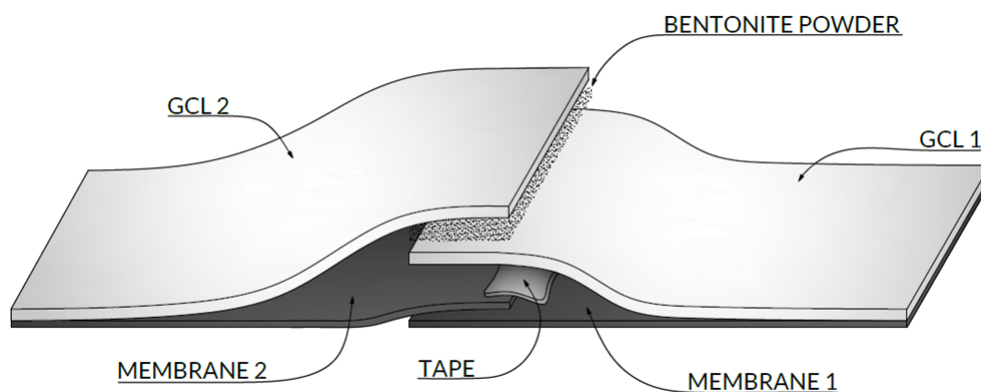

INSTALLATION

Geomembrane on the top

1. To combine the two panels, the foil shall be folded. Both edges of the liner are not glued, so there shall be no problem with folding the whole panel (40 m). The width of the glue-free margin is 300 mm.
2. The bentonite shall be poured on the edge of one panel (in this case on panel 1).
3. The panels shall be combined by placing the panel 2 on the margin of panel 1. There is a layer of bentonite between those two panels. Now the panels are ready for phase two of combining.
4. The surface of the foil shall be cleaned with acetone or similar agent.
5. This action secures the integrity of combining. Clean membrane surface before combining is a must. The membranes of the two panels shall be overlapped in the same order. First the membrane from the panel 1 and then from the panel 2.
6. The tape shall be placed in the middle of the combining spot, so that the half of the tape shall be on a left side and the other half on the right side of the combining line.

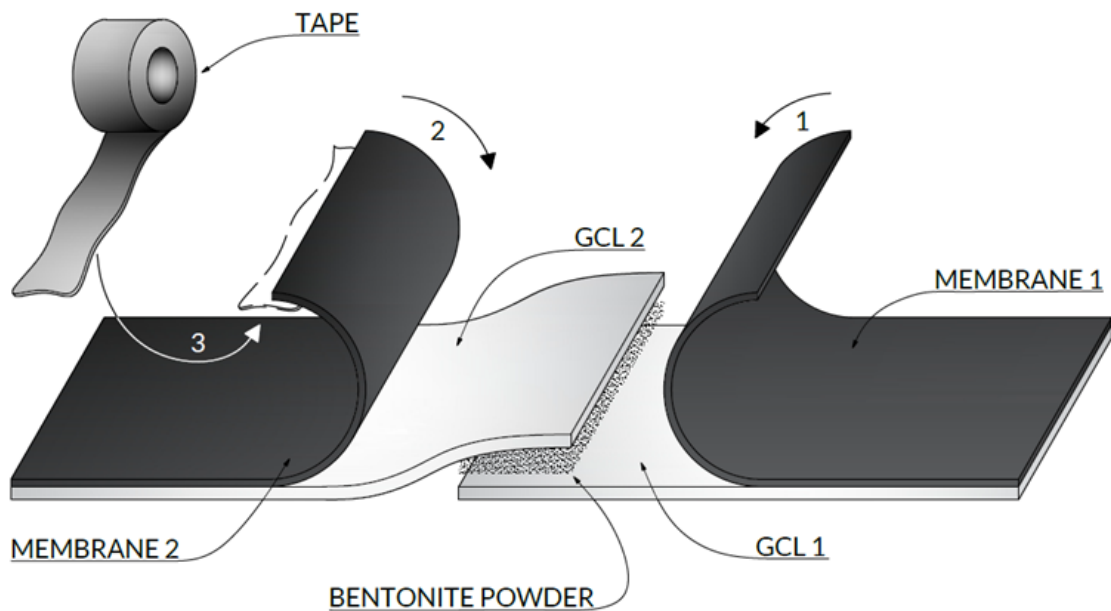

NOTE:

To combine two panels of GCL CS we recommend single-sided, self-adhesive bitumen waterproofing tape which maintains excellent adhesion even at low temperatures.

Recommended width: approx. 100 mm

Geomembrane welding

When using GCL with a geomembrane that is thick enough to allow welded joints (from 0,6 mm and up), follow the instructions above with scenarios one or two. In principle, the steps for laying the individual layers do not change, only the form of joining the geomembrane is different.

Geomembrane on the bottom - welding

1. The GCL shall be folded so that the Geomembrane can be visible.
2. The surface of the Geomembrane shall be cleaned using acetone or similar agent. This action secures the integrity of combining. Clean membrane surface before combining is a must.
3. The Geomembrane of the panel 1 shall be covered with Geomembrane of the panel 2, creating overlap.
4. Welding shall be done in accordance with geomembrane welding principles.
5. After combining the Geomembranes, left GCL shall be unfolded, covering the geomembranes.
6. The bentonite shall be poured on the edge of one panel (in this case 1 one).
7. The panel 2 shall be unfolded, covering the layer of bentonite and left panel.
8. Now the panels are ready for the next phase of the combining. There shall be some space without bentonite for the leister.
9. The overlap shall be combined with leister In order to secure the Integrity of the bond and avoid the separation.

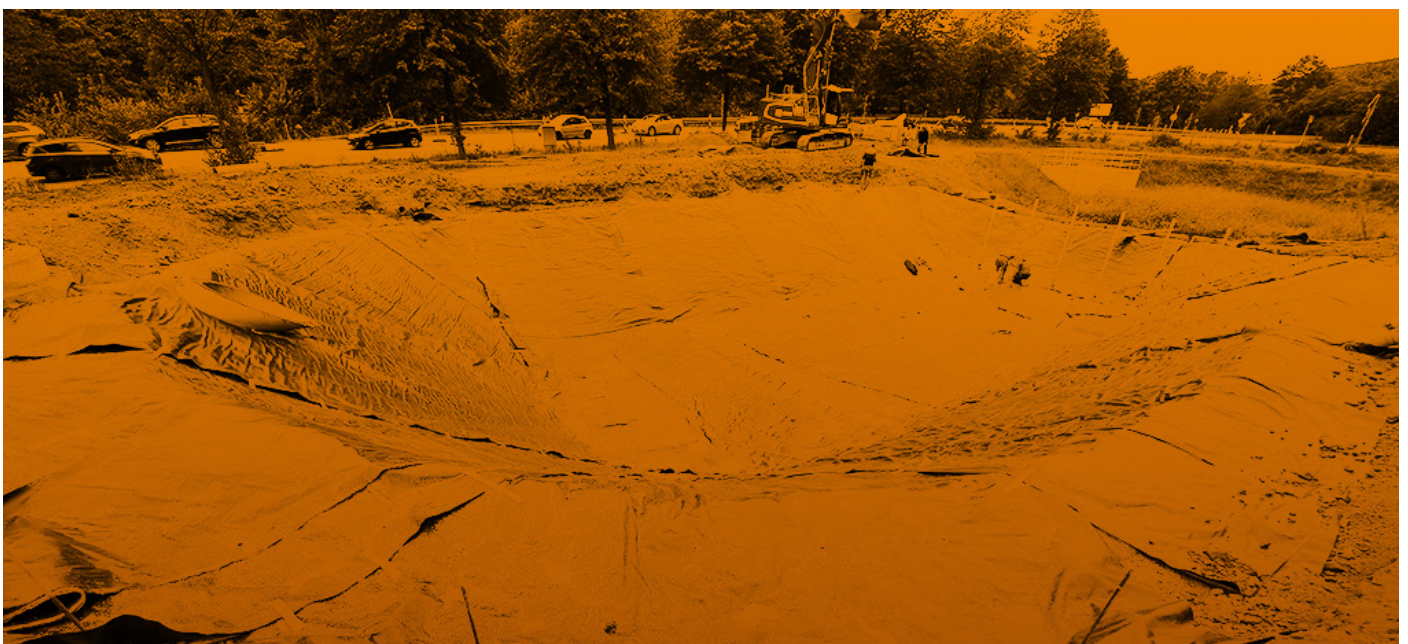
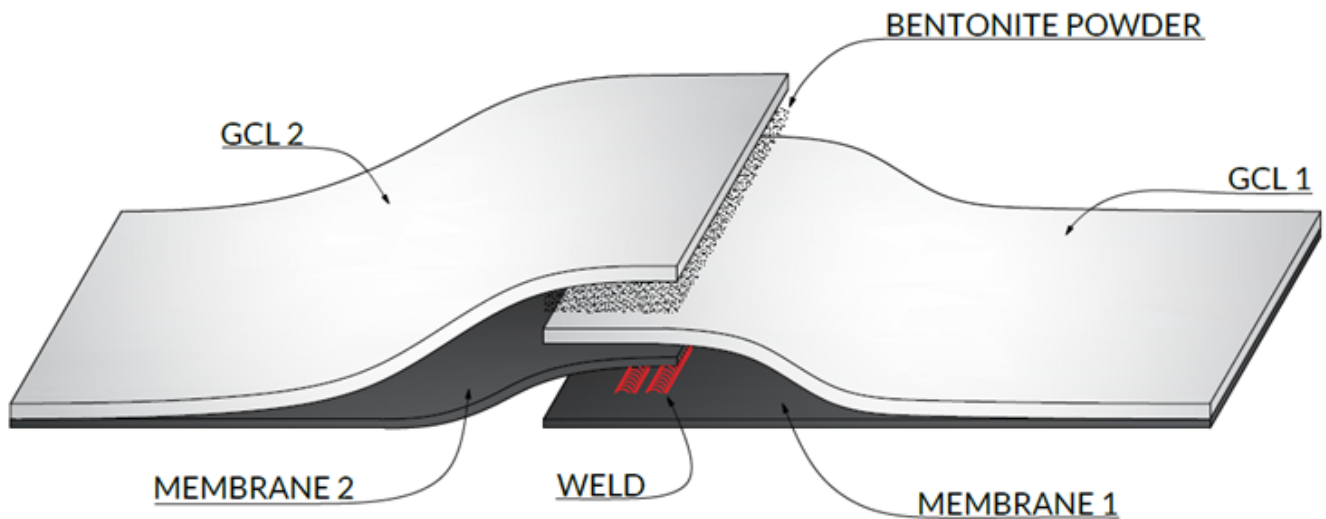

INSTALLATION

Geomembrane on the top - welding

1. To combine the two panels, the foil shall be folded. Both edges of the liner are not glued, so there shall be no problem with folding the whole panel (40 m). The width of the glue-free margin is 300 mm.
2. The bentonite shall be poured on the edge of one panel (in this case on panel 1).
3. The panels shall be combined by placing the panel 2 on the margin of panel 1. Between those two panels is a layer of bentonite. Now the panels are ready for phase two of combining.
4. The surface of the foil shall be cleaned with acetone or similar agent.
5. This action secures the integrity of combining. Clean membrane surface before combining is a must. The membranes of the two panels shall be overlapped in the same order. First the membrane from the panel 1 and then from the panel 2.
6. Welding shall be done in accordance with geomembrane welding principles.

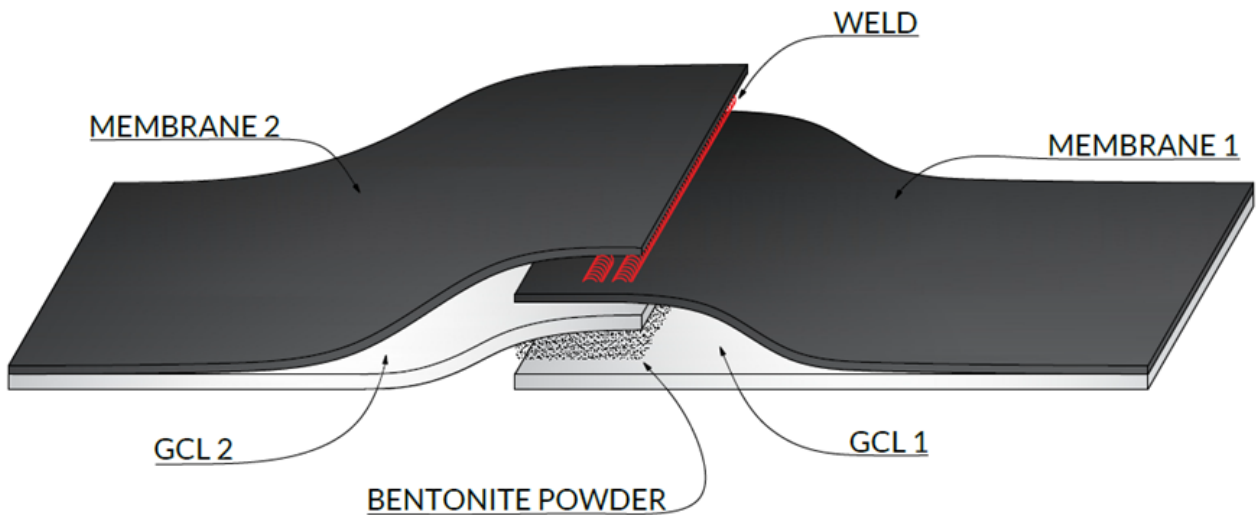

NOTE:

For welding waterproofing membranes we recommend machines with adjustable parameters: temperature, speed and air flow.

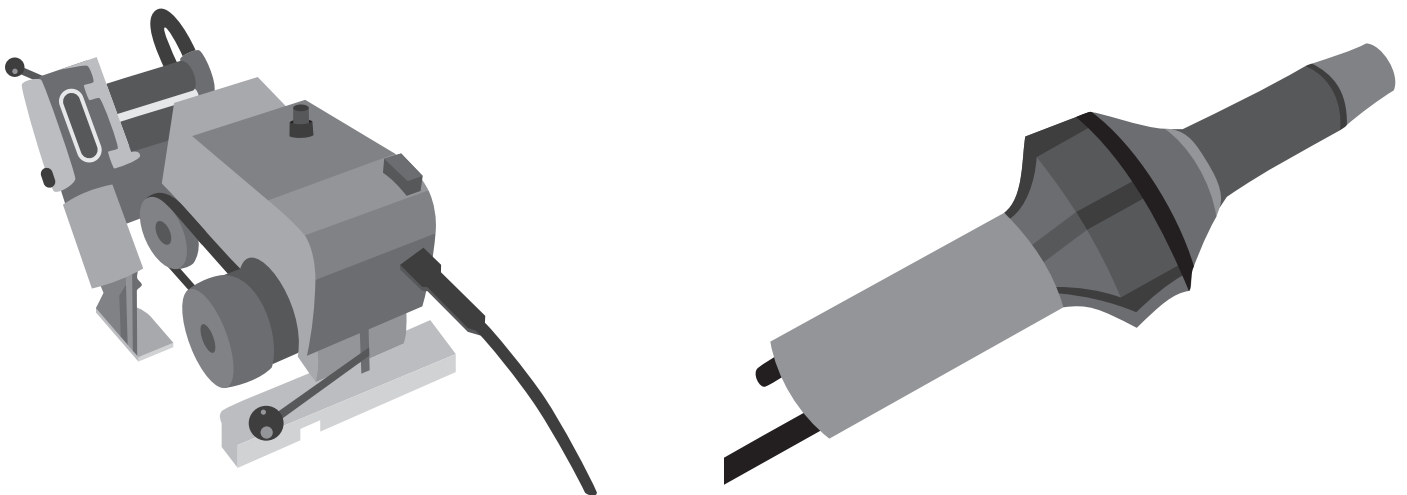

Hand-operated equipment may be helpful to seal difficult areas.

12.3. Installation on slopes

The stability of EUROBENT waterproofing system components on slopes should be evaluated individually for each project. There are many variables that require different installation techniques. Eurobent can help in this respect on request.

In all cases, it is required that the responsible designer approve the slope stability analysis of the installation.

EUROBENT panels should be laid towards the slope and anchored at the top of the slope. End or transverse overlaps on steep slopes should be avoided. If overlaps on slopes are unavoidable, contact Eurobent for custom extra-long GCL rolls that we can produce if required. If this is not possible, then the transverse overlaps must follow the direction of water flow.

The cover soil should not be applied from the top to the bottom of the slope.

12.4 Anchor Trench

The end of the GCL roll should be placed in the anchor trench at the top of the slope, unless otherwise specified in the design. The forward front edge of the trench should be rounded to eliminate any sharp sharp corners that could cause excessive stress on the GCL. Loose soil should be removed or compacted at the bottom of the trench.

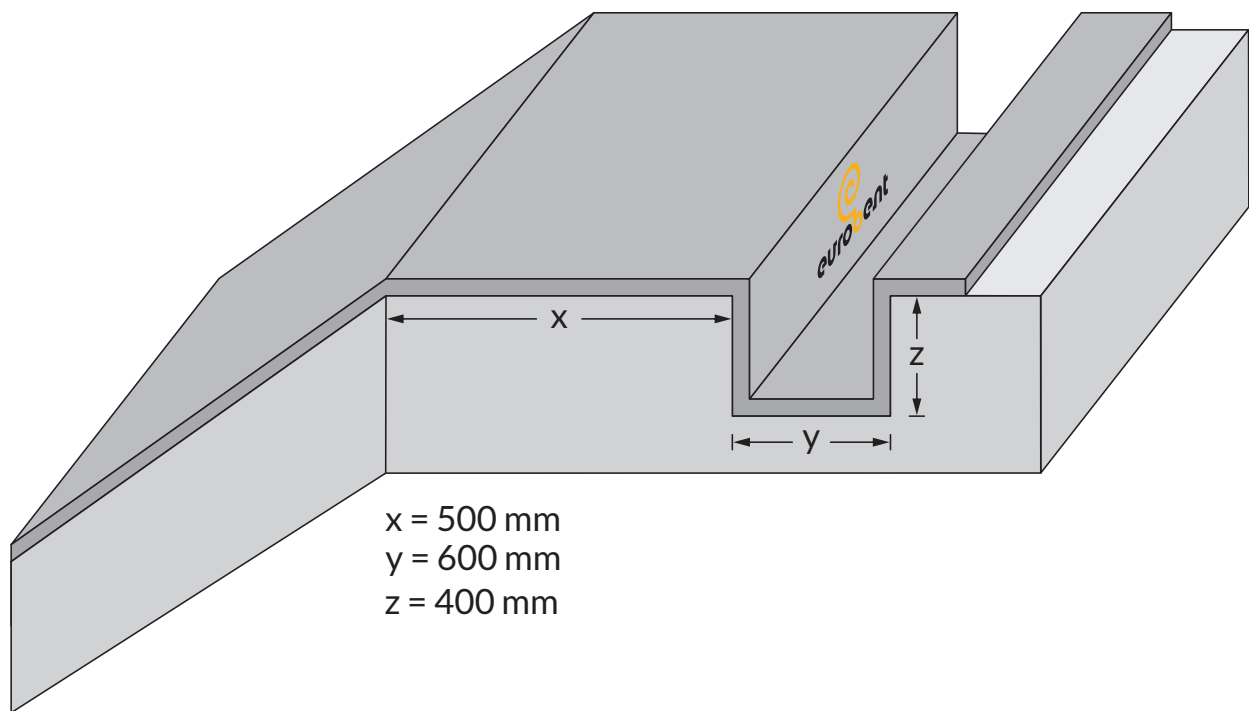

If a trench is used to anchor the end of the GCL, a backfill of soil should be placed in the trench to allow the GCL to be anchored. The size and shape of the trench, as well as appropriate backfill procedures, shall be in accordance with the drawings and project specifications.

In most cases, a depth of 40-50 cm and a width of 60 cm is sufficient. The trench must be backfilled and compacted.

The GCL should be placed in the anchor trench so that it covers the entire trench floor but does not extend to the back wall of the trench.

12.5. Connections & Penetrations

Before installing the EUROBENT GCL around the pipe, clear an area 15 - 20 cm deep and 30 cm around from the surrounding soil. Fill this area to half of its total depth with bentonite powder or EUROPASTE and place the GCL, which is to be cut in a star shape to fit the pipe, on it. Then fill the rest of the excavated area with bentonite powder and place another sheet of GCL cut in a star shape on top of it. To hold the second bentonite liner in place, it is recommended to attach it with a pipe jacket.

Overlaps around joints, transitions, and where panels intersect should follow the same overlap rules as for joining individual GCL panels.

- Integration with coarse compacted clay liners is shown in Figure 1;
- Cutoff trenches using EUROBENT GCL in cohesive soils are typically constructed as shown in Figure 2;
- Fixing and sealing at concrete structures can be done as shown in Figures 3 and 4. These typical connections are suitable where the structure must be sealed to heights above and below the maximum water containment level. To ensure water tightness, temporarily fix the EUROBENT GCL panel vertically to the structure (as shown in the drawing) to allow backfilling; Penetrations, such as pipe channels, are typically made as shown in Figure 5.

Further connection methods and penetration details can be discussed with Eurobent.

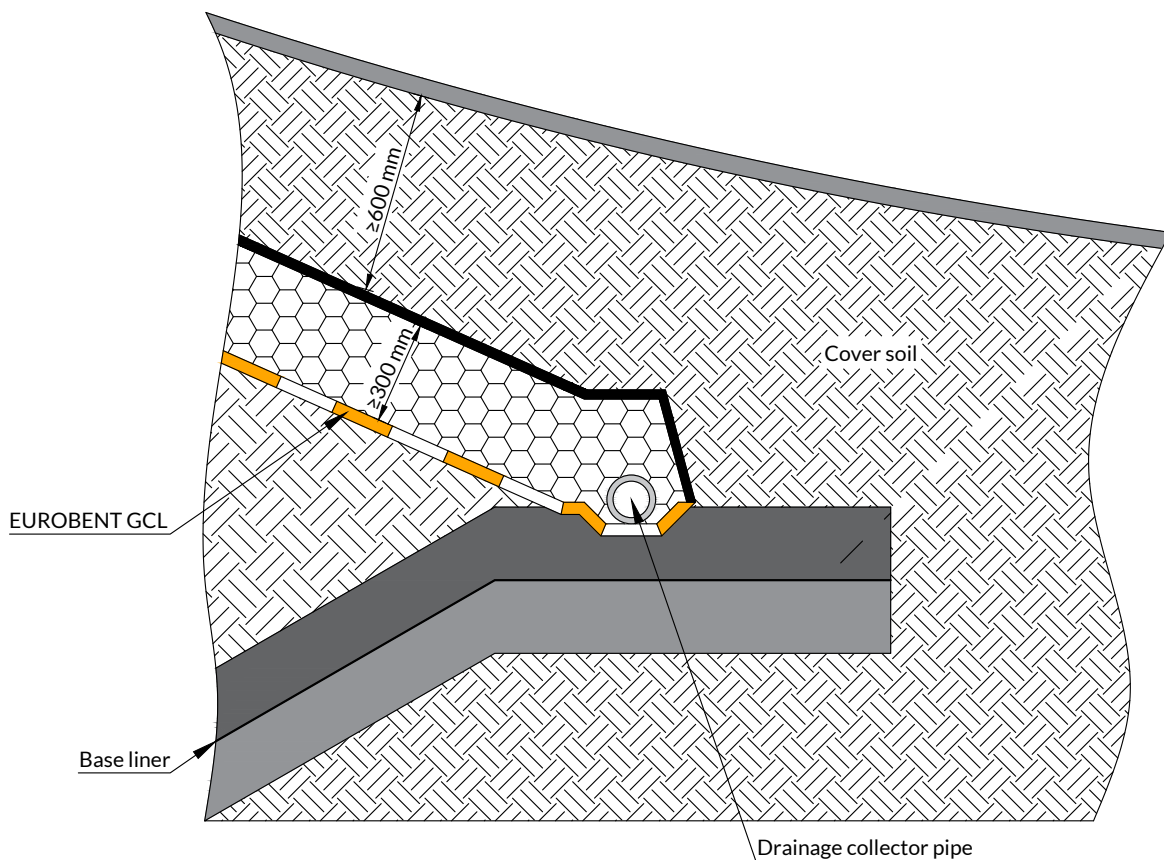

Fig 1.

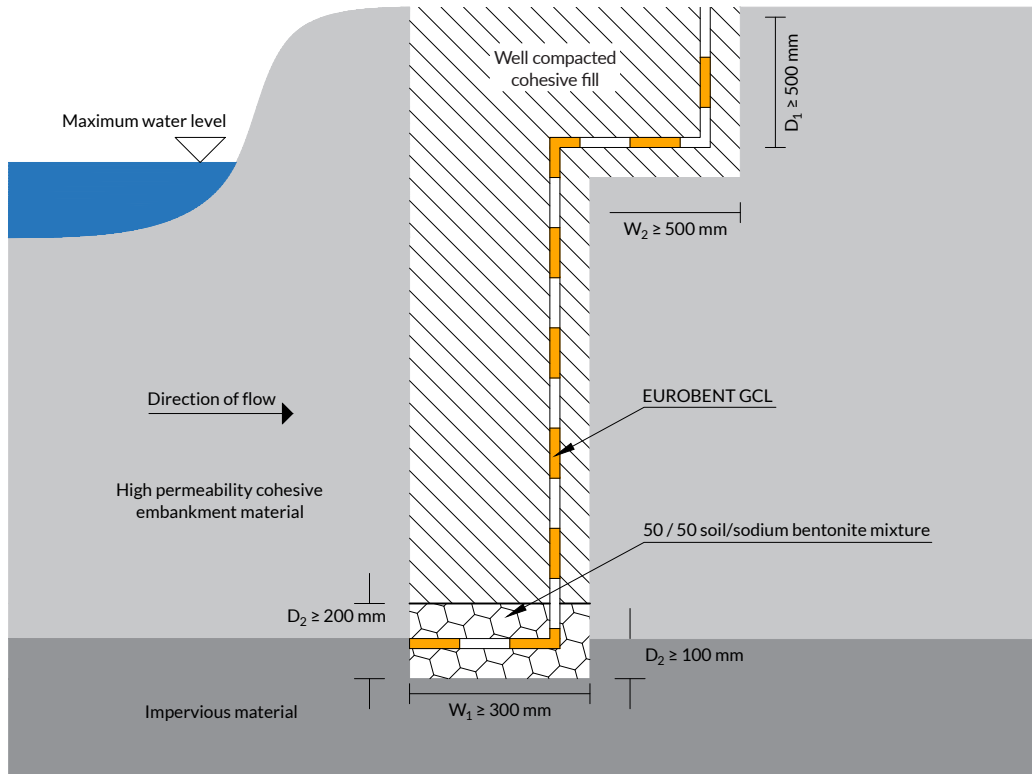

Fig 2.

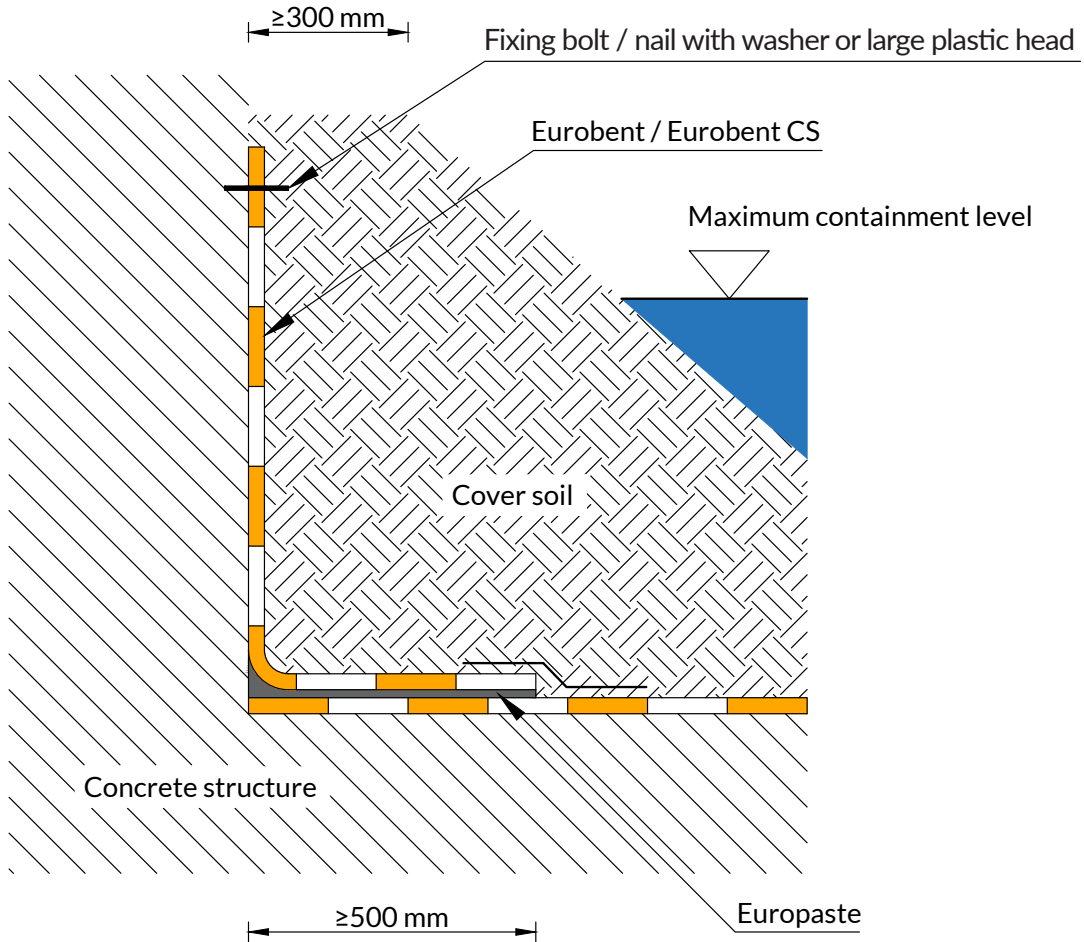

Fig 3.

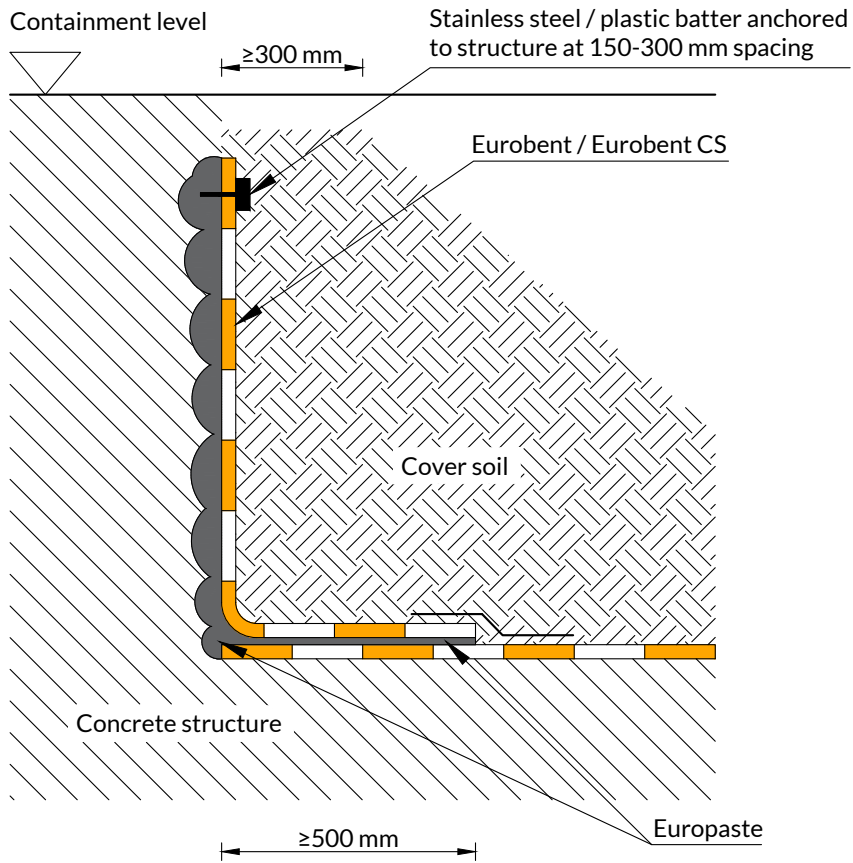

Fig 4.

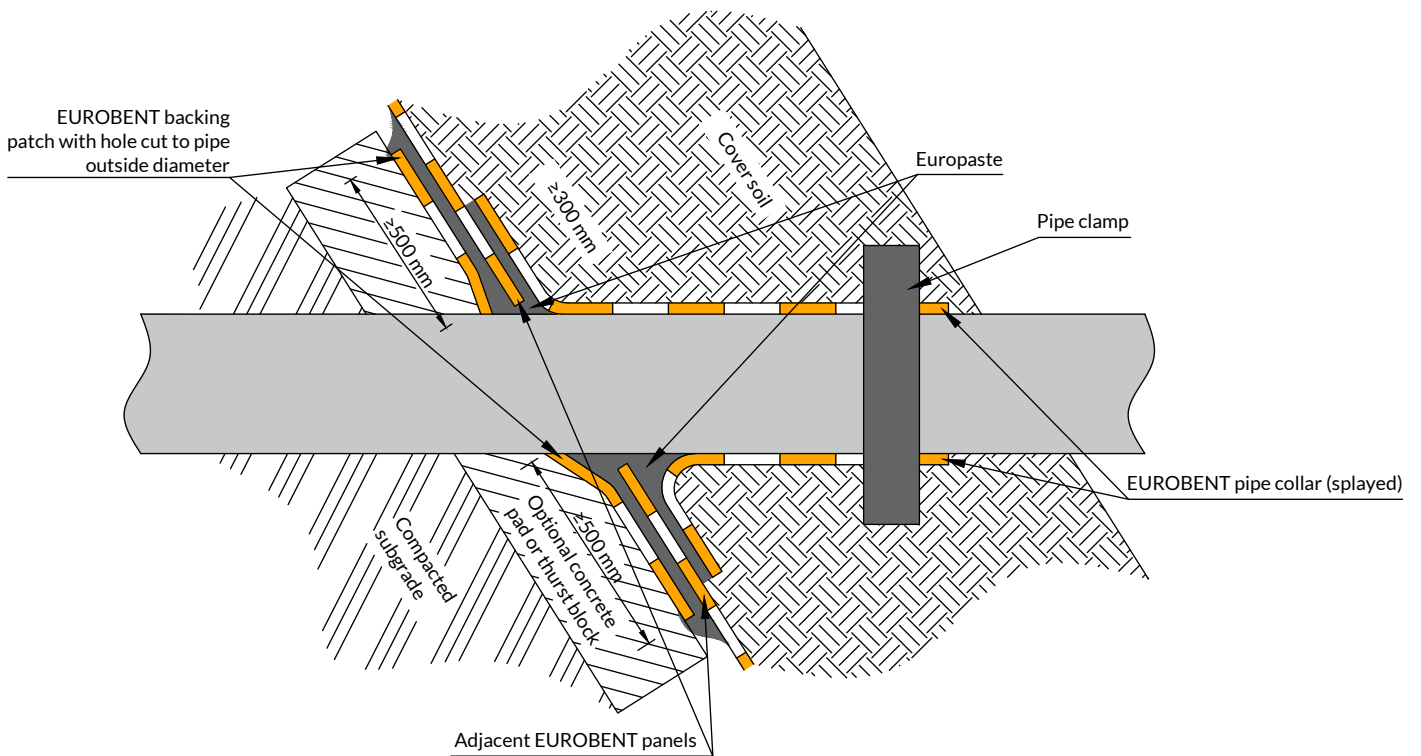

Fig 5.

INSPECTION

13

13. INSPECTION

After placement an authorized person should perform a thorough visual inspection of the EUROBENT GCL rolls and seams. This should be done immediately after placement is completed.

The inspection should cover overlaps, alignment, penetrations, joints, detection of any defects including installation damage. Detected Improperly Installed areas should be marked and fixed. Repairs should be inspected and approved by the project engineer or authorized person.

The inspection/repair process should be carried out as soon as possible to ensure that no defective area is left unrepaired.

Once the inspection is completed, the next layer of geosynthetics can be laid or the soil can be spread in a manner that is not detrimental to the installed GCL.



INSPECTION

DAMAGE REPAIR

14

14. DAMAGE REPAIR

Even if installation is carried out with utmost care, the liner may be damaged in the process. Due to the swelling properties of the bentonite, minor defects will heal and seal themselves. More serious defects should be marked immediately and repaired by cutting a patch of EUROBENT GCL large enough to allow an overlap of at least 30 cm on all edges. Place the bentonite powder on the repaired area and cover it with the patch.

Depending on site conditions, it may be necessary to use an adhesive, such as wood glue, to fix the patch in place to prevent its movement during installation of cover layer. Smaller patches may be tucked under the damaged area to prevent patch movement.

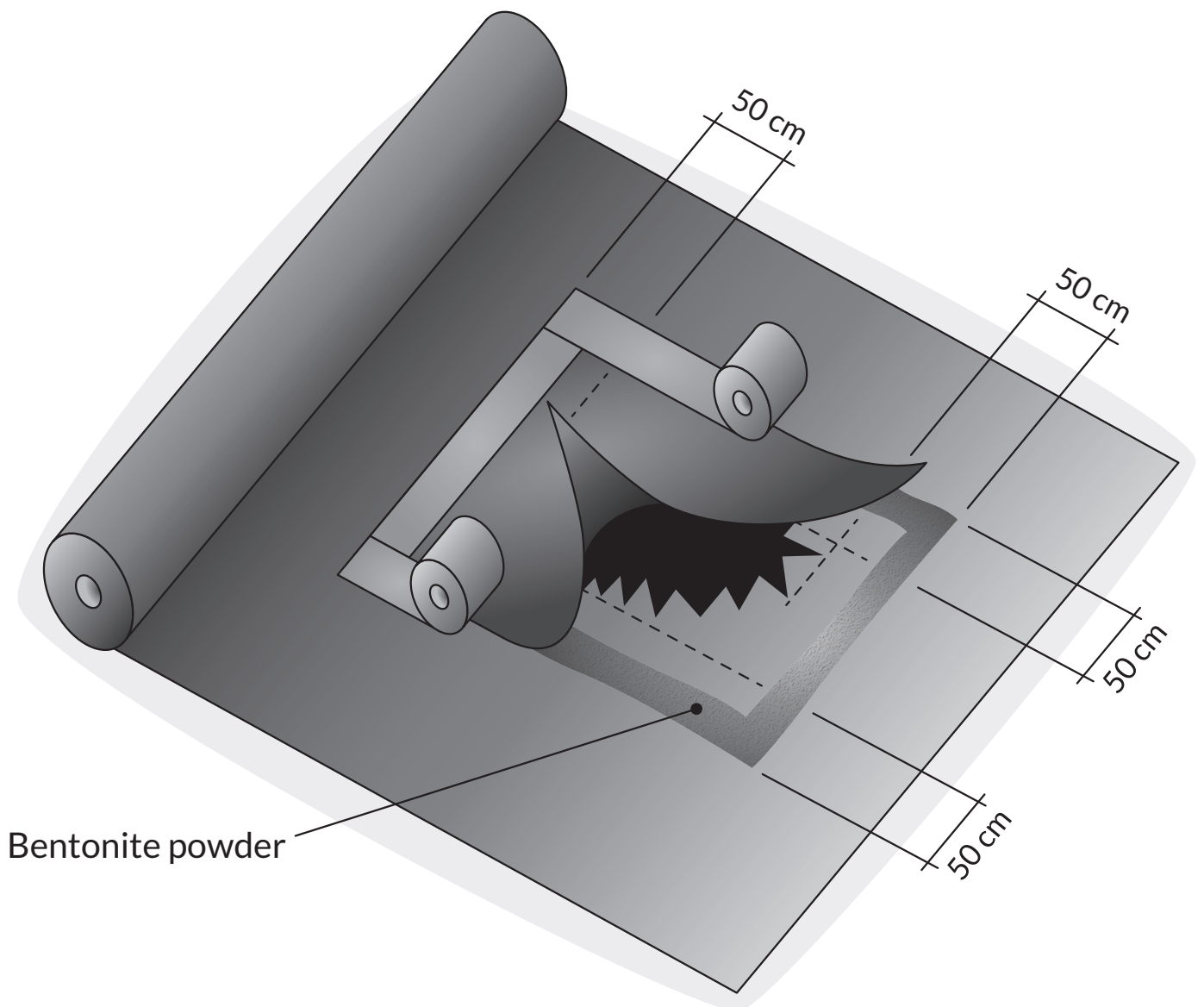

PREPARATION FOR PLACING SOIL COVER

15

15. PREPARATION FOR PLACING SOIL COVER

In the event that EUROBENT is not covered by topsoil as a counterweight, a temporary plastic layer (for example, a geomembrane) shall be placed on the same working day after deployment to protect the GCL from premature hydration.

If the deployed EUROBENT panels have hydrated (for example during rainfall) without counterweight, special operating conditions may be required during the placement of the cover soil. In this case, contact Eurobent to determine the suitability of the waterproofing material.



PREPARATION FOR PLACING SOIL COVER

SOIL COVER PLACEMENT

16

16. SOIL COVER PLACEMENT

Cover material should be placed on the bentonite liner immediately after installation. Soil cover shall be placed over the GCL with construction equipment that minimizes stress on the GCL. A minimum thickness of 300 mm of cover material should be maintained between any equipment tires/tracks and the GCL at all times. In areas of high-traffic or roadways, a minimum thickness of 600 mm is required. Soil cover should be placed in a manner that prevents the soil from entering the GCL seams.

On slopes, the soil layer should be laid from the bottom of the slope towards the top.

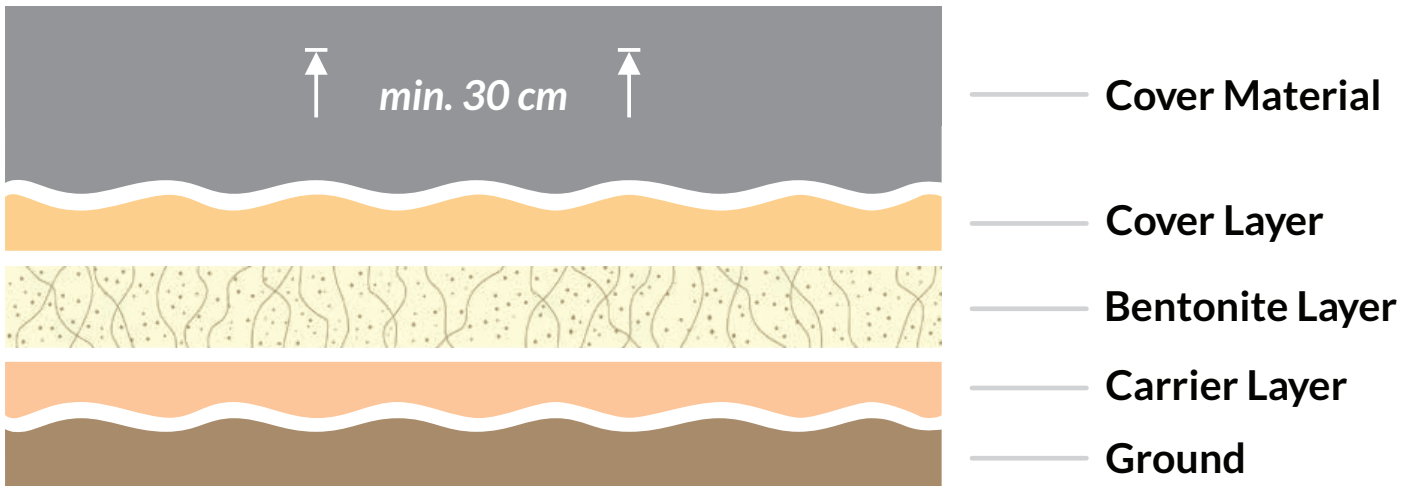

SOIL COVER PLACEMENT

HYDRATION

17

17. HYDRATION

In most cases, hydration of the GCL is achieved by natural rainfall or water is absorbed from the ground. In some cases, however, it is necessary to activate the GCL before it begins to work. This may be the case in dry regions where the groundwater level is too low and there is no rainfall.

At landfill openings, the GCL also needs to be activated before the landfill is filled so that the GCL will start working with uncontaminated water.

If it is necessary to hydrate the GCL, it is best to do so after the topsoil is covered so that adequate counterbalance and confining pressure is provided.

Hydration can be done with both hydration systems and water sprinkling. However, avoid strong jets of water that could damage/displace the topsoil.

Hydration of the GCL before covering with topsoil does not necessarily mean that it needs to be replaced. Make sure that:

- GCL has not been damaged or torn
- GCL has not swollen to a thickness that may suggest both geotextile layers are not bonded together
- GCL overlaps are made in a proper way
- Bentonite powder on overlaps has not been washed out
- There was no excessive movement on the wet GCL



HYDRATION

TERMS & CONDITIONS

18

18. TERMS & CONDITIONS

The engineering design for a specific site should be done after the site survey has provided all necessary information.

The evaluation of appropriate safety factors for each specific project must always remain the responsibility of the design engineer.

This manual includes two forms that are helpful for daily installation reports and for GCL inspection.

Forms 1 & 2 are attached to the manual.



18.1. Installation form

INSTALLATION FORM	
Project Name/Number	
Installation date	
Weather conditions	
Numbers of installed rolls	

INFORMATION ABOUT CONDITIONS OF STORAGE IN A YARD AND ON-SITE.	
Rolls covered	Yes <input type="checkbox"/> No <input type="checkbox"/>
Rolls labeled	Yes <input type="checkbox"/> No <input type="checkbox"/>
Standing water present	Yes <input type="checkbox"/> No <input type="checkbox"/>
Packaging damage	Yes <input type="checkbox"/> No <input type="checkbox"/>
Rolls damage	Yes <input type="checkbox"/> No <input type="checkbox"/>
Subgrade surface acceptable	Yes <input type="checkbox"/> No <input type="checkbox"/>
Installation area dry	Yes <input type="checkbox"/> No <input type="checkbox"/>
Anchor trenches acceptable	Yes <input type="checkbox"/> No <input type="checkbox"/>
Cover soil acceptable	Yes <input type="checkbox"/> No <input type="checkbox"/>
Anchor trench fill compacted	Yes <input type="checkbox"/> No <input type="checkbox"/>
All seams visually inspected	Yes <input type="checkbox"/> No <input type="checkbox"/>
Seam bentonite added (as applicable)	Yes <input type="checkbox"/> No <input type="checkbox"/>
All detail work inspected	Yes <input type="checkbox"/> No <input type="checkbox"/>
All mat covered at end of day	Yes <input type="checkbox"/> No <input type="checkbox"/>

*If there are defects or deficiencies that need to be noted, use the Remarks section

REMARKS

18.2. Goods receipt form

GOODS RECEIPT FORM		
Delivery date		
		Notes*
Container/truck number match the packing list	Yes <input type="checkbox"/> No <input type="checkbox"/>	
Rolls numbers match the packing list	Yes <input type="checkbox"/> No <input type="checkbox"/>	
Condition of packaging (in case of damage, describe the damage in the description section, indicating the roll numbers)	Yes <input type="checkbox"/> No <input type="checkbox"/>	

* If you need to make a note, enter the note number from the description section in this field.

REMARKS / NON-CONFORMITY

.....
Date and signature of the person reporting the delivery



eurobent
KEEP ROLLING

Eurobent Sp. z o.o.
Kliczkowska 42
58-100 Świdnica
Poland

tel. +48 74 852 13 19
www.eurobent.com
office@eurobent.com